



## Sport 35 Executioner

LOA:	35' / 10.67 m
Beam:	8'6" / 2.6 m
Weight, Dry:	8,500 lbs.* / 3,855 kgs
Fuel Capacity:	160 gals. / 606 L
Freshwater Capacity:	13 gallons / 49 L
Draft w/ Drive Down:	35" / 0.9 m
Recommended Power:	
Twin Mercury 425 HP 496 HO w/ Bravo 1-X	
Speed:	78+ mph
Hull Warranty:	6 Years
Cruise (Fuel) at 58 mph:	36 gph
WOT (Fuel) w/Twin 425 Mercury:	
70 gph at 78 mph	
Maximum Cruising Range:	
232 miles at 90% capacity	

Be advised that performance figures are merely an estimate of what you can expect based on our factory testing program. The above listed speeds are verified by GPS with one test driver and less than forty (40) gallons of fuel. Boat speeds, fuel mileage and range can vary depending on weight, fuel load, number of passengers, air temperature, altitude, humidity, barometric pressure, water conditions, wind, engine tuning, horsepower (HP) variance from engine to engine, propellers, canvas and numerous other factors beyond our control. Cruising range calculated at 90% tank capacity. Fountain Powerboats reserves the right to make changes on standard and optional equipment at any time without prior notice. Useable fuel in a gas tank may be slightly less than the advertised fuel capacity.

\*Boat weights can vary depending on optional equipment.

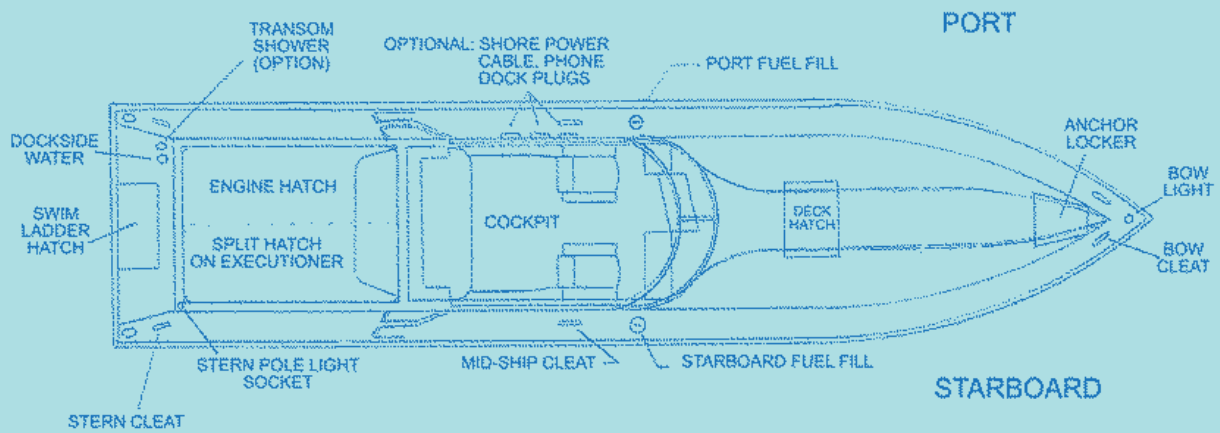

## Features

- Batteries, twin, heavy duty/jumper cables and receptacle
- Bolster seats w/electric drop down
- Cabin lighting
- Fire extinguisher, automatic
- Head, enclosed w/porta potti
- Bilge pumps, two, 12 volt DC, 1200 GPH automatic/manual pump
- Carpeting, cockpit, customized w/embroidered Fountain logo
- Fresh water flush
- Cockpit billet accents include: step pads, vents, & cockpit rails
- Engine compartment w/lighting and motorized hatch
- Rails, bow and stern, 316L stainless steel, thru-bolted
- Cockpit cover, form fitted including windshield, upgraded material
- Horns, electric
- Rubrail with stainless steel insert
- Hour meter
- Slimline cleats, pop-up with deck bezels
- Fuel filters, (2) w/water separators
- Stereo, marine AM/FM CD w/four marine speakers
- Fuel tanks, heavy duty, baffled, 3/16" thick aluminum; foamed, glassed & bolted in position w/stainless steel pickups, 160 gal. total capacity
- Windshield, tinted
- Throttles, billet race
- Trim indicators, mechanical for drives and tabs
- Trim switch on throttles
- Bilge blowers, (2)
- Bow lights, pop-up with deck bezels
- Compass, electronic digital
- Graphics, standard selection
- Battery switches, two, parallel, explosion proof
- Cabin, customized
- Dash with monster gauges; carbon fiber, including carbon fiber glovebox lid and surround, color coordinated throttles, gauge rims, wheel hub & steering wheel
- Hand laid composite hull and deck manufactured w/multi-directional fiberglass, w/high density coring and Interplastic vinyl ester resin and w/hull and deck laminated, thru-bolted, screwed and sealed together w/heavy duty marine sealant/adhesive
- Depth gauge
- Galley w/sink and cold water pressure system
- Super ventilated positive lift hull, single step
- Engine mounts, heavy duty plate
- Ice chest, built-in, insulated
- Engine room billet accents includes: battery box w/ chrome engraved step pad, fender holders, hatch rams, water fills (blue only), trim pump caps, motor well panel, sea strainer

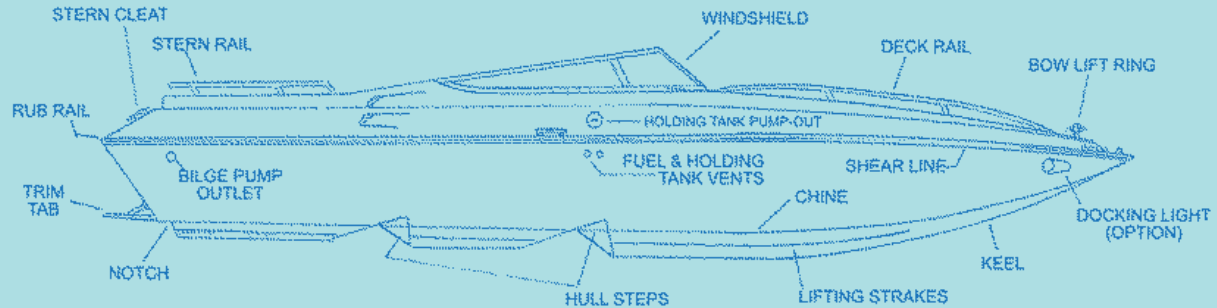

## Features

- Satellite radio, Sirius or XM
- Sun deck, upholstered over engine hatch w/custom "X" logo
- Instrumentation, heavy duty Livorsi gauges w/ integrated warning lights, GPS speedometer, Screen Display - Vessel View
- Windshield frame, powder coated
- Steering, heavy duty hydraulic, offshore hi-performance, tie bar, external
- Fuel vapor detector
- Propellers, stainless steel to match engine and drive package
- Sea strainers
- Trim tabs, heavy duty hydraulic, offshore hi-performance

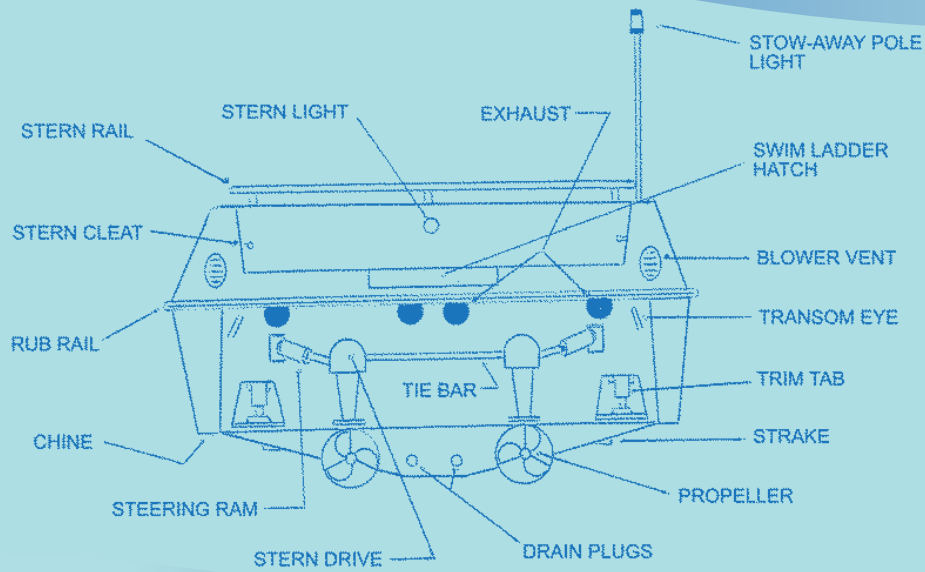

Options

- CE Certification Kit
- Deck Graphics
- Hatch, Colored Mirror With Logo
- Oscillating Fans in Cabin (2)
- Refrigerator in Wet Bar
- Shipping Cradle
- Shower, Transom (Fresh Water)
- Storage Cover over Gunwale



1st 4 Boats (UK)  
Tel: +44 1202 760942

1st 4 Boats (Cyprus)  
Tel: +357 238 32232

sales@1st4boats.com

www.1st4boats.com